



Optical Detection of Magnetic Resonance

Adele Menezes, Chelsey Ramer, Dr. Hans Van Tol

National High Magnetic Field Laboratory, Florida State University, Tallahassee, FL



INTRODUCTION

BACKGROUND

- Electron Paramagnetic Resonance (EPR) is a form of spectroscopy that is used on unpaired electrons to test their reactivity, structure, and dynamic behaviour.
- One of the main flaws of EPR is that you need many spins ($\sim 10^{12}$) to detect a short-lived signal using low-energy microwave photons
- One of the ideas is the use of high-energy photons, visible light, to measure the amount of energy (in the form of phosphorescence) released by unpaired electrons.
- For the researchers and post-docs at the National High Magnetic Field Laboratory (NHMFL) the largest roadblock in applying optics to their current EPR machine is the sample holder
- The goal was to design a sample holder to be used for the Heterodyne Quasi-Optical Spectrometer at the NHMFL.

METHODS

- We used 3-D Modeling software Fusion360 to design an optimized sample holder for our electron paramagnetic resonance spectrometer.
- One optimization technique we introduced to our sample holder was 'set screws' which allow the position of the sample within the holder to be moved with precision in order to find its ideal point of optical detection.
- To measure the power of our sample holder, we first performed an experiment with an unmodified sample holder that lacked any optical mechanisms with a pentacene sample.
- We will next experiment on the same pentacene sample using our optimized sample holder to record and find the hopefully optimized data exhibiting higher levels of optical detection and triplet spin states.

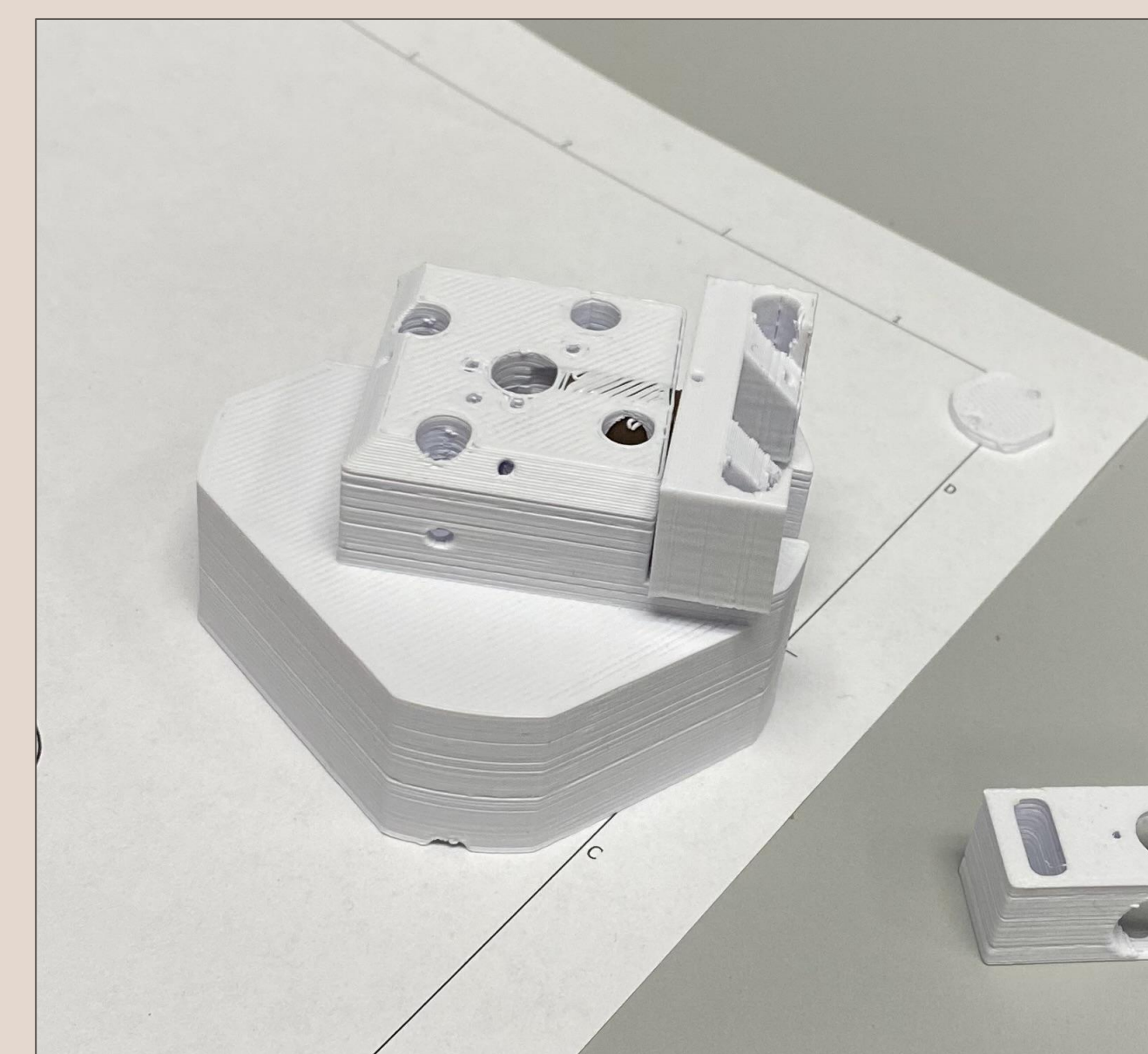
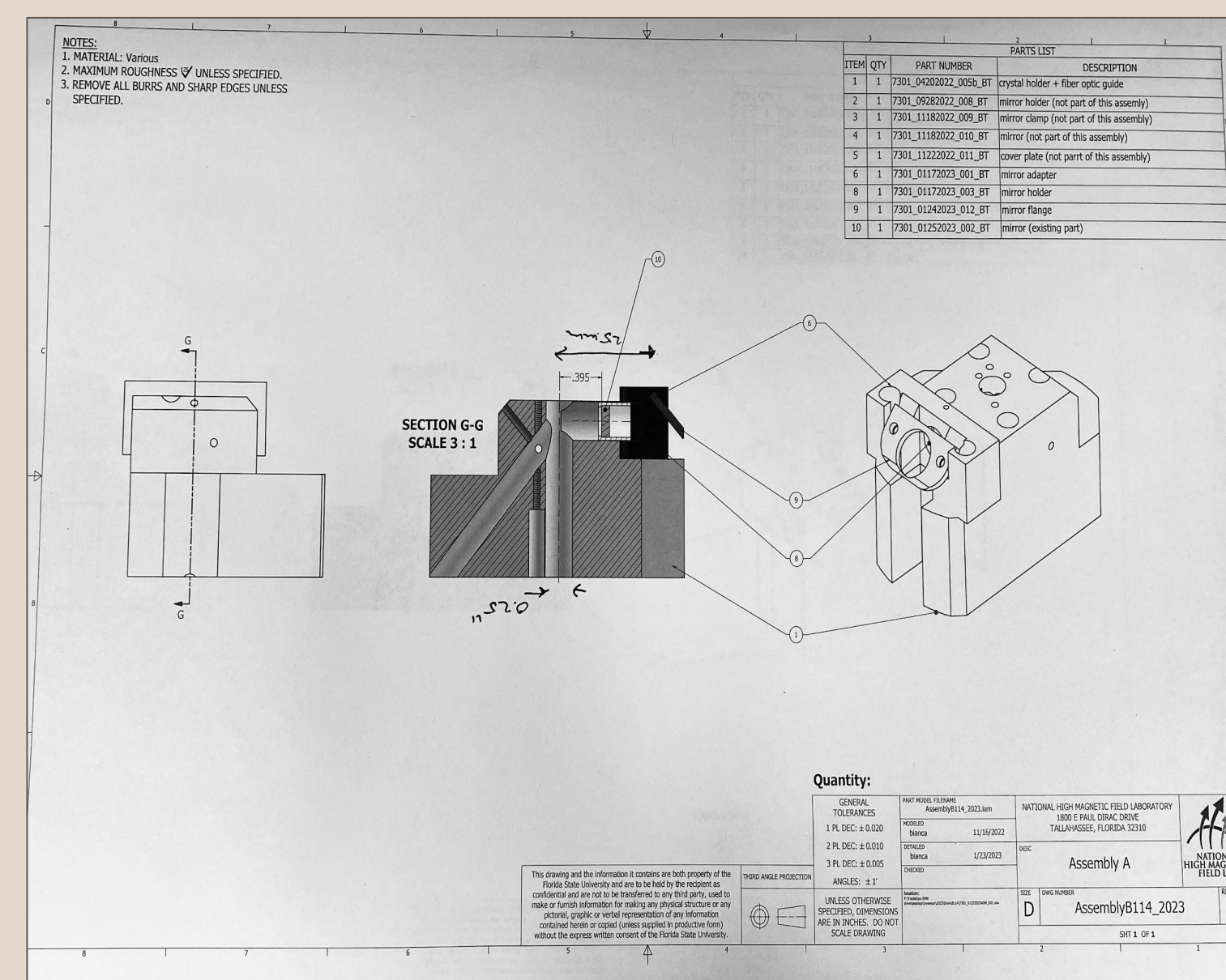

CONCLUSION AND FUTURE DIRECTIONS

- Though the design is preliminary, it could represent a significant achievement in the field of EPR spectroscopy. The 3D software used (Fusion 360) allowed for a precise and detailed representation of the sample holder, including its internal and external structures.
- Transferability to other quasi-optical EPR machines may be limited.
- Sample holder could greatly improve our understanding of the sample's behavior and lead to a more comprehensive analysis of its properties.
- In the future, the goal would be to fine-tune the specifications of the sample holder.
- This would require the researchers to test the efficacy of the sample holder using a model made from aluminum, which was not able to be obtained for the project.

REFERENCES

Carbonera, D. (2009, February 24). Optically detected magnetic resonance (ODMR) of photoexcited triplet states. University of Wuerzburg. Retrieved November 11, 2022, DOI 10.1007/s11120-009-9407-5

Spaeth, J.-M., & Overhof, H. (n.d.). Optical Detection of Electron Paramagnetic Resonance. Springer Link. DOI: 10.1007/978-3-642-55615-9_4

RESULTS

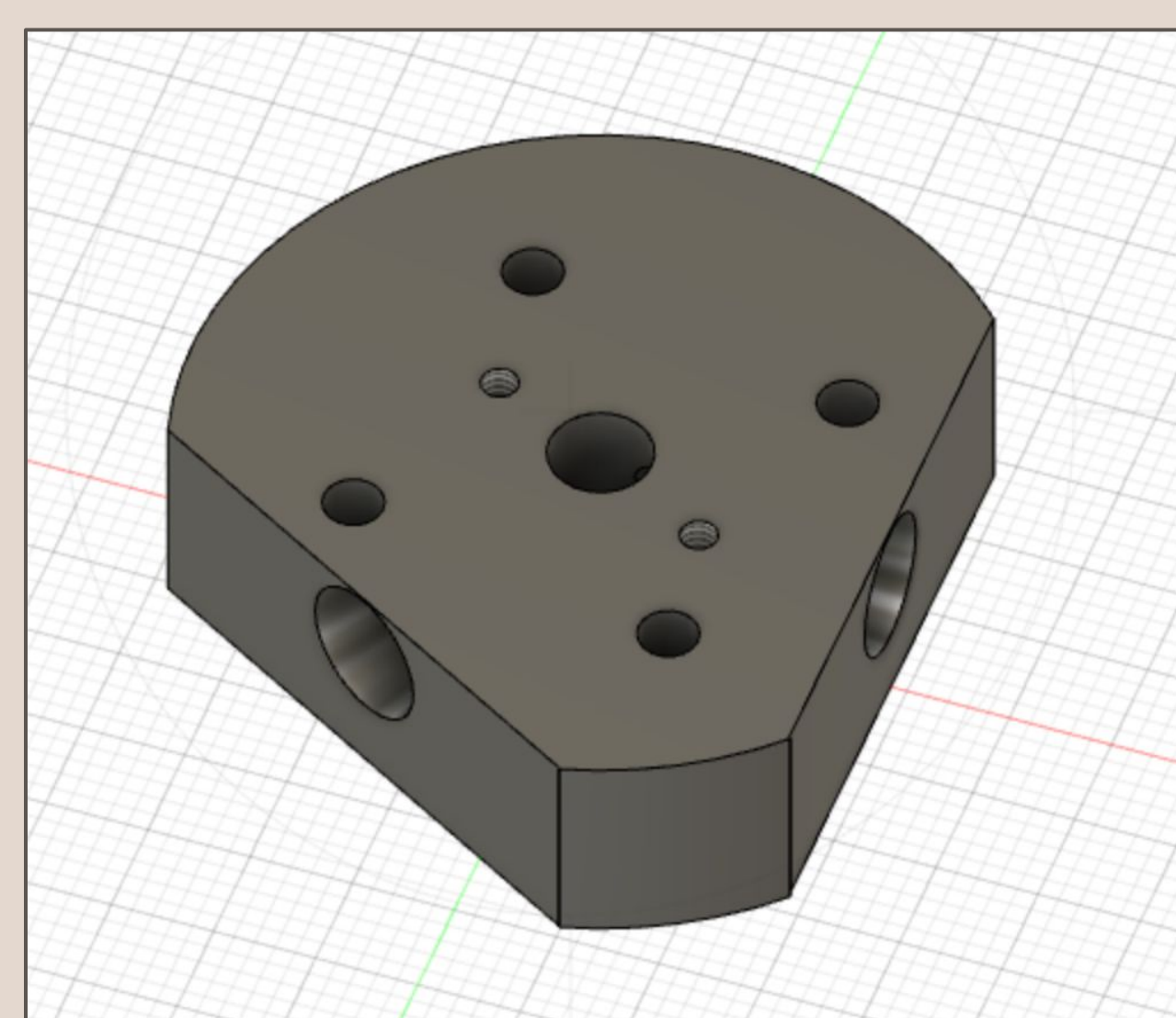

To the right, the attachment by which a mirror will reflect phosphorescence into a quartz rod. On the left, the sample holder itself.

