



# Developing an Adaptive Professional Development Model for School Professionals' Implementation of Shared Reading Activities



Maggie Acquaviva, Jillian Kessler, and Dr. Kelly Farquharson, PhD, CCC-SLP

Florida State University, School of Communication Science and Disorders, Tallahassee, FL

## Abstract

This study was motivated primarily by past obstacles faced when training educators and speech-language pathologists (SLPs) to implement **dialogic reading strategies** with school children. Dialogic reading is a systematic form of interactive shared book reading with positive effects on the development of children's oral language skills and could have similar benefits with students with disabilities. This study, driven by the need to reevaluate the approach to training educators in this technique, also may yield crucial information on the effectiveness of different professional development (PD) training components for future use in schools.

This study seeks to create PD training modules to aid educators and SLPs with the implementation of dialogic reading skills for the purpose of improving children's literacy. Participants will submit three self-recordings of shared reading sessions with young children ages 3-8 years, in order to establish a baseline. After they are coded and analyzed, the participants will receive a video training module instructing them on the implementation of the **Prompt, Evaluate, Expand, Repeat (PEER) technique**. Finally, they will re-record the sessions using tools learned in the PD module, which will be coded using a web-based video-coding program, Vosaic, and analyzed by Microsoft Excel to determine if further coaching is needed, in which case this will take place in the form of individualized Zoom sessions and they will be given written and verbal feedback. This is an ongoing two-year trial and data collection is still underway. The expected date of completion is the end of summer 2025.

## Purpose

Since this study is focused on language development and speech of young children, it follows that the subjects of early childhood educators and speech language pathologists would be able to provide an adequate environment for observation. Additionally, they would be likely to benefit the most from the training modules as they can be implemented directly in instruction with children. The goal of this PD program is to find a developmentally-appropriate and timesaving technique that can easily be implemented into school districts to increase children's literary abilities.

## Methods

Participants will submit three self-recordings of shared reading sessions with young children ages 3-8 years, in order to establish a baseline of their skills. Then, after the content of the recordings have been coded and analyzed, the participants will receive a video training module instructing them on the implementation of the **PEER technique**. The PEER technique, which stands for Prompt, Evaluate, Expand, and Repeat, consists of four different criteria of print referencing. The participants will re-record shared book reading sessions using tools learned in the professional development module, which will be coded using the program Vosaic and analyzed by Microsoft Excel to determine if further coaching is needed. If the participant achieves 80% or higher accuracy with use of the PEER technique, they will not require additional coaching and will be considered finished with the study. If they do not achieve at least 80% accuracy, then further coaching will take place in the form of individualized Zoom sessions and the participant will be given written and verbal feedback. The participant will then record more sessions and following this, if more coaching is still needed, in stage three the participant will get the same individualized Zoom sessions, but the coach will also add a reflection component to understand where the participant is having trouble.

Figure 1. PD Model Design

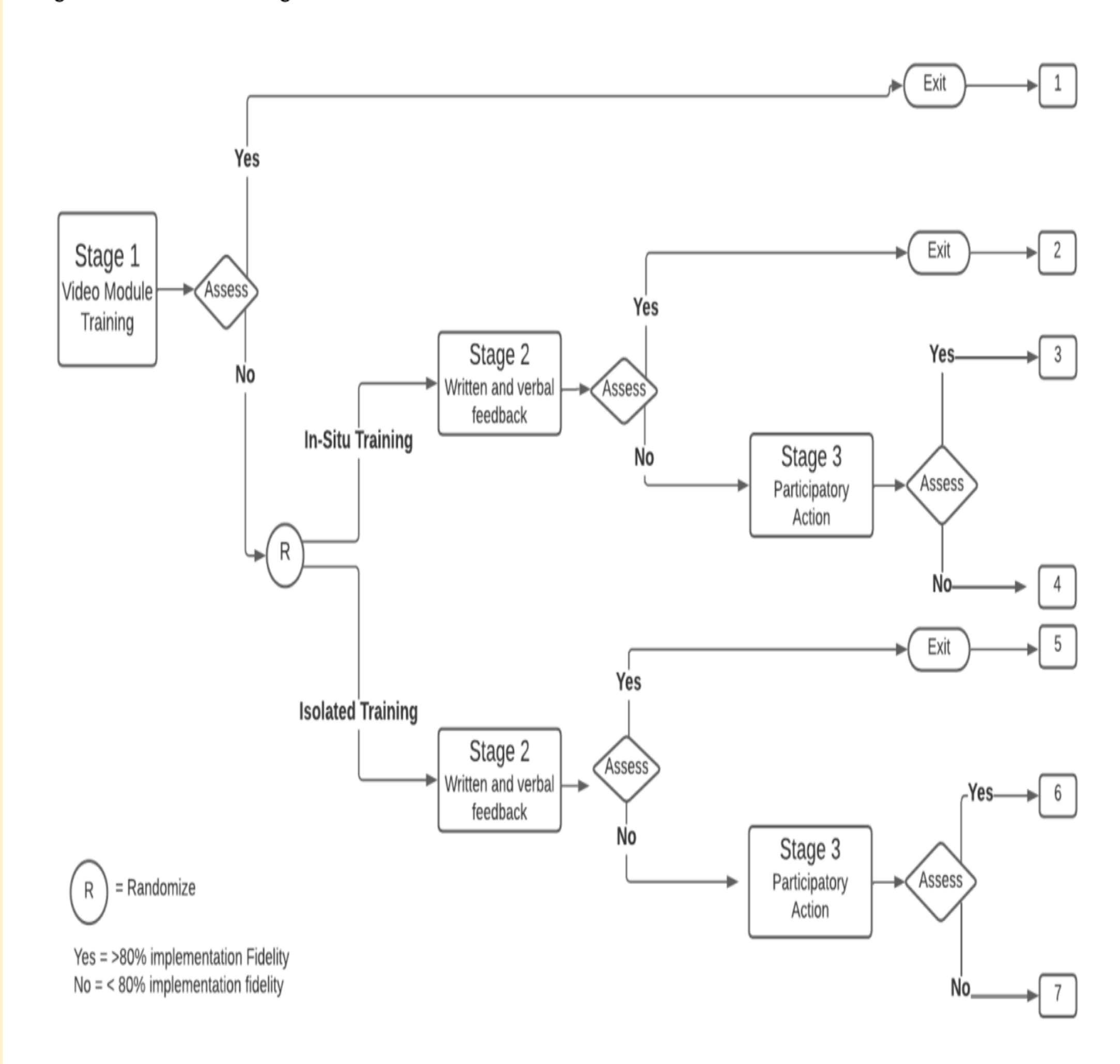

Appendix A  
Visual Diagram of Methods

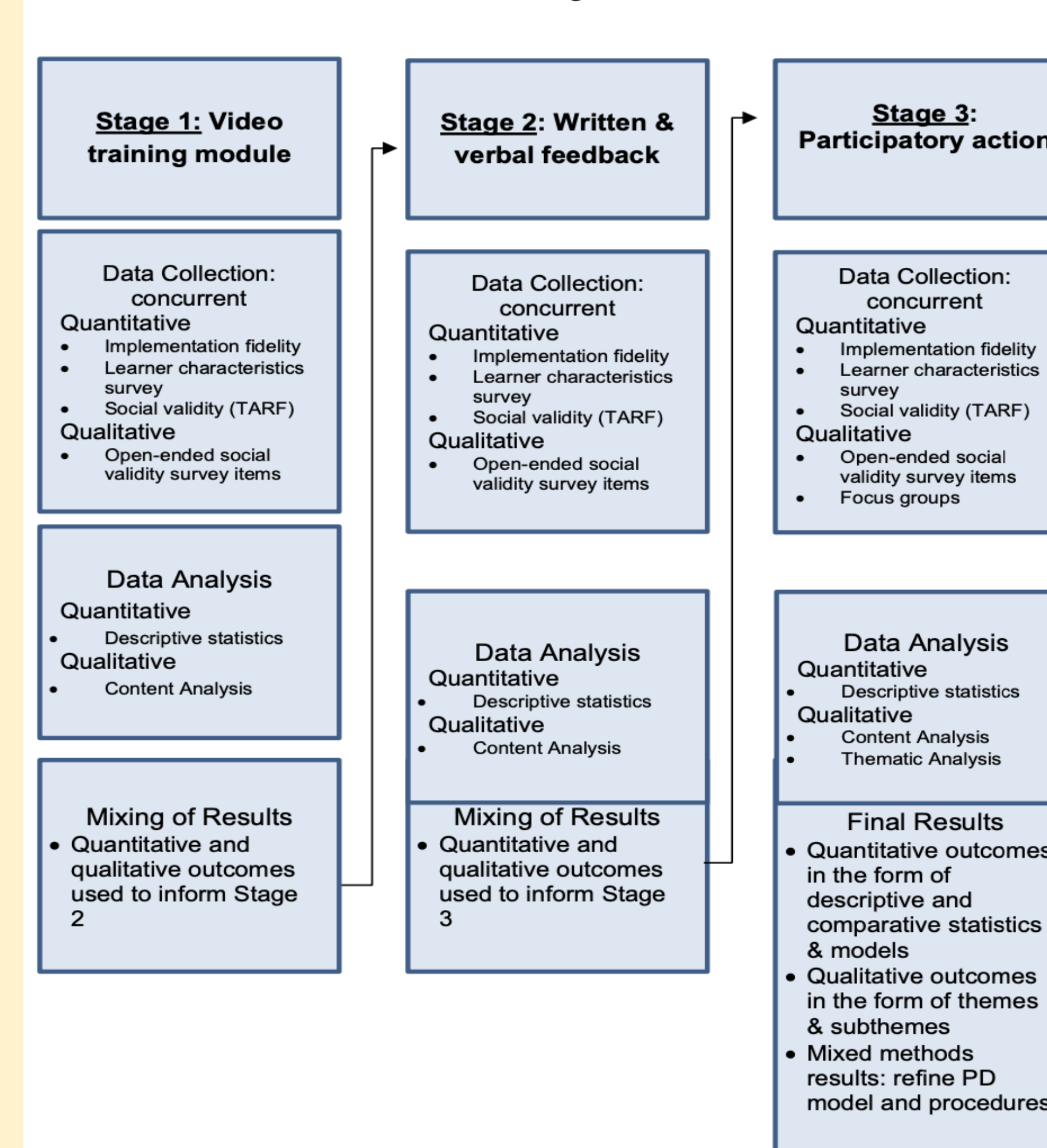

## Conclusions

Currently, this is an ongoing 2-year trial and data collection is still underway. The expected date of when this trial will be completed is the end of summer 2025. However, we hope to have some preliminary results in the near future that can be showcased. Future results of this study may be useful in reshaping PD programs in school districts as well as highlighting the importance of dialogic reading in children's literacy development. Participation in this study has not only increased our knowledge of the effectiveness of dialogic reading strategies, but also highlighted several components central to conducting research such as the value of strict coding schemes and the importance of data analysis methods. Additionally, our part has been enhanced by the research team's emphasis on in-depth training for coding and related research roles, as well as the importance of maintaining a clear line of communication and committing to clear outlines.

## References



## Acknowledgements

We would like to thank Dr. Kelly Farquharson for giving us this opportunity and helping us grow as researchers. We would also like to thank Dr. Lindsay Dennis, Dr. Veronica Fleury, Crystal Ladwig, and Mary Allison Moody for their contributions to this project and the guidance they have given us as well.